

Argent Data Systems ADS-SR1 Simplex Repeater User's Manual

Revised 8-1-2010

Firmware revision K



Argent Data Systems
PO Box 579
Santa Maria, CA 93455

(800) 274-4076
Fax (866) 302-6890

www.argentdata.com

Copyright © 2008-2010 Argent Data Systems
All Rights Reserved

Warranty

If this product fails due to defects in materials or workmanship during the period of one year from the date of purchase, or if the flash memory in this device fails through normal usage during the period of five years from the date of purchase, Argent Data Systems will repair or replace the device, at our option.

This warranty covers defects in manufacturing discovered while using the product as recommended by the manufacturer. The warranty does not cover loss or theft, nor does coverage extend to damage caused by misuse, abuse, unauthorized modification, improper storage conditions, lightning, or natural disasters.

Should the product fail, your sole recourse shall be repair or replacement, as described in the preceding paragraphs. We will not be held liable to you or any other party for any damages that result from the failure of this product.

Damages excluded include, but are not limited to, the following: lost profits, lost savings, lost data, damage to other equipment, and incidental or consequential damages arising from the use, or inability to use this product. In no event will Argent Data Systems be liable for more than the amount of your purchase price, not to exceed the current list price of the product, and excluding tax, shipping and handling charges.

Argent Data Systems disclaims any other warranties, expressed or implied. By installing or using the product, the user accepts all terms described herein.

To obtain service under this warranty, contact us at support@argentdata.com or at 1-800-274-4076.

Introduction

The ADS-SR1 is a multi-function simplex repeater, voice mailbox, and voice announcement system. It can be used with almost any radio (handheld, base station, or mobile) and is equally suitable for permanent installation or temporary use for emergencies and special events. Features of the ADS-SR1 include:

- 218 seconds total recording time
- 19.2 kHz sample rate for excellent voice clarity
- 10 voice announcements with independent timers
- Up to 20 voicemail messages
- Programmable maximum message length setting
- Messages and settings retained for 20 years with no power
- Optional Morse code or voice identification
- DTMF remote control for all functions
- Operates from two AA batteries or external 4-28 V DC supply
- Runs for weeks on alkaline or lithium batteries
- 'Say again' function repeats last received transmission on command
- 'Stand by' tone or message option lets users know repeater is in use
- Selectable courtesy tones
- Audio output adjustable in hardware and by remote command
- PTT modes for handheld and mobile radios
- Upgradeable software for future enhancements
- Programmable security code with auto-lock feature
- Unit remains controllable even with stuck receiver squelch
- 1 year warranty on complete unit, 5 years on flash memory

What is a Simplex Repeater?

Most radio operators are familiar with the concept of a duplex repeater, where a separate receiver and transmitter operate at the same time, listening on one frequency and retransmitting on another. Duplex repeaters allow natural conversation, but they're typically bulky and expensive because of the elaborate filters required.

A simplex repeater, on the other hand, is a store-and-forward device. It records incoming transmissions and re-sends them on the same channel. It can provide the same extension of coverage and range as a duplex repeater, with the obvious

drawback of requiring twice as much air time to carry out a conversation, as each transmission is repeated back. However, their simplicity and low cost makes them perfect for temporary or emergency use, and to provide coverage in areas where the cost of a duplex repeater can't be justified.

For many radio clubs and emergency response organizations, a single semi-portable duplex repeater is a major investment. Simplex repeaters like the ADS-SR1, on the other hand, are inexpensive enough to be kept as individual equipment for each member, making it more likely that they'll be available for rapid deployment when needed. An emergency repeater station can be set up with nothing more than a handheld radio, a cable, and the repeater unit itself.

The ADS-SR1 has additional features that make it useful as more than just a simplex repeater. For example, the 'say again' feature can be used to repeat a single missed message on demand, even with the normal repeater function disabled. This is particularly useful in situations where most stations are close enough to hear each other directly and normal operation of the repeater would be distracting.

The voice announcement features of the ADS-SR1 can be used independently of the repeater functions, and can be used for such things as club activity reminders or foxhunt beacons, or even a slow-scan TV beacon. The voicemail feature functions like an answering machine for your radio, recording up to 20 incoming messages and allowing them to be retrieved with a separate access code, independent of the main security code.

Legal Issues

Legal restrictions on the operation of a simplex repeater depend on the radio service used (i.e., amateur, commercial, FRS, MURS, etc) and vary from country to country. Interpretations of specific rules vary as well, and their applicability to operation of the ADS-SR1 may depend on which specific features are used. It is the responsibility of the end user to ensure that they operate within applicable regulations.

Hardware Description

The ADS-SR1 measures 3.6" by 2.6" by 1.1" (92mm by 66mm by 28 mm). Its front panel has a pushbutton power switch, 2.1x5.5mm center-positive DC power jack, and an RJ45 jack for all radio connections. Two LEDs (one red and one green) on the RJ45 jack indicate activity. A removable panel on the back of the unit provides access to the battery compartment and DIP switches. Setting the DIP switches may require a small object like a paperclip or pin. These switches select the PTT mode and audio output range, and allow the device to be reset to its default settings.

Power is supplied by internal batteries, through the DC power jack, or through the RJ45 jack.

Installing Batteries

The ADS-SR1 accepts two AA (LR6) size batteries. Use fresh alkaline or lithium batteries, and pay close attention to battery polarity. Do not install batteries if the unit is being powered through the RJ45 jack!

Do not store the unit for long periods with alkaline batteries installed. If long-term storage is required, use premium grade lithium batteries (e.g., Energizer Lithium) and inspect them periodically. Lithium batteries provide significantly longer operating life for the unit and can be stored for longer periods of time. Because the ADS-SR1 may be stored in your emergency kit for years without being used, lithium batteries are highly recommended to ensure that the unit will work when it's needed.

Radio Interfacing

The RJ45 jack on the front panel provides all radio interface connections. Looking into the front of the connector, the pin functions, from left to right, are as follows:

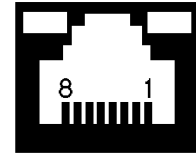

- 8 - Power in (typically used with radios that provide a +8v output)
- 7 - Unused
- 6 - Audio in (from radio's speaker output)
- 5 - Push-to-talk output
- 4 - Ground
- 3 - Audio out (to radio's microphone input)
- 2 - Ground
- 1 - Squelch / COR input

The Squelch / COR input is optional. When this signal is available from the radio (usually from an accessory or data connector) it allows the repeater to be operated with the VOX delay.

The PTT mode must be set appropriately for the radio being used. Most base station and mobile radios use a separate PTT input. Many handheld radios, with the notable exception of most Kenwood models, combine the microphone and PTT signals. For combined PTT models, DIP switch 4 in the ADS-SR1's battery compartment must be set to the ON position. All other radios should have switch 4 set to OFF.

Do not install batteries when using the optional RJ45 power input pin. The DC jack, however, may be used while batteries are installed.

Audio Levels

For good performance, it's important to set both receive and transmit audio levels correctly. The receive audio level is set using the radio's volume control. To set it correctly, use another radio for testing. Transmit a test message in an ordinary speaking voice and observe the red and green LEDs on the front of the ADS-SR1.

The green LED will turn on when the audio level is about 75% of full scale. The red LED is normally on and will switch off when the level exceeds 100%. Set the

volume of the radio connected to the ADS-SR1 so that the green LED flickers in response to your voice, without the red LED dimming noticeably.

Setting the transmit audio level is a two-step process. First, the range can be set roughly using DIP switches 1 and 2. The audio level will be lowest with both switches off, and highest with both switches on.

When set properly, the transmitted audio should sound natural and not distorted or 'clipped', without being excessively quiet. The ##98 command will cause the unit to transmit a 1 kHz tone at full amplitude for several seconds, to help with adjustment. If you can't find a combination of DIP switch settings that yields a comfortable audio level, it can be further adjusted using a DTMF command, detailed below.

Operation

When repeater mode is enabled (as it is by default), the ADS-SR1 listens for activity and automatically starts recording when audio is detected. If the red light does not come on in response to radio activity, check that the volume level of the radio is set correctly.

A period of silence (initially set to two seconds) tells the ADS-SR1 that the transmission is finished, and it then keys the radio and retransmits the message.

Many mobile radios provide a squelch, COR/COS, or 'busy' signal that can be used with the ADS-SR1's squelch input. This allows the VOX delay to be eliminated. See the section on the squelch input function for more information.

If no time limit has been set, the repeater will record until its memory is full. Remember that the 218 second memory is shared between the current message being recorded, the previous transmission (if 'say again' mode is enabled) and any stored voicemail messages and announcements. If the unit runs out of space, it will wait until the current transmission ends before repeating as much as it was able to record.

If a time limit is set, the repeater will record only to this limit and will then immediately transmit what it recorded, even if the sender is still talking. If the cool-down timer is enabled, the unit will stop repeating until the timer expires. This helps prevent transmitter overheating, and allows a repeater with a stuck squelch to be controlled, as it will still respond to commands even while the cool-down timer is active.

The ADS-SR1 responds to a number of DTMF commands. Normal commands start with '##'; access to these commands can be restricted through the use of a 3-digit security code.

A few commands can be used without a security code. Pressing '0' activates the 'say again' function (if enabled) and causes the repeater to retransmit the last transmission heard, even if hours or days have passed. However, the 'say again' memory is not retained when the unit is powered off.

The record voicemail command, '1', can also be entered without a security code. See below for more information on voicemail functions.

Entering '*' at any time during a transmission causes the repeater to ignore the current transmission, and aborts any commands being entered. This can be used to prevent the unit from retransmitting your message, or to correct a mistake while entering a command. Pressing '*' followed by the 3-digit voicemail access code enters voicemail retrieval mode, detailed below.

If the repeater auto-off timer is enabled, pressing '3' will turn on the repeater function. The repeater function will shut off again after the unit has been idle for the specified time or when the '6' command is received.

The 'stand by' tone or message option, when enabled, alerts users of the repeater that a transmission is being recorded. This helps to prevent doubling, but results in the first portion of the incoming transmission being dropped. When this option is enabled, allow an extra second or so after keying the microphone before talking.

Messages

The ADS-SR1 has 10 message slots, numbered 0 through 9. These messages can be configured as timed announcements (each with a selectable interval and time offset), automatic responses to incoming transmissions (often for ID or operating instructions), or they may be triggered manually by DTMF command.

Command Reference

All normal commands start with '##', followed by at least two digits. If the unit is locked (either because the lock command '##00' was entered or because the auto-lock function was enabled and the timer expired), no commands will be accepted until '##' and the 3-digit security code have been received. For example, if the code is '123', entering '##123' unlocks the unit.

If the repeater has trouble receiving commands, try adjusting the audio input level. Each time a valid DTMF tone is received, the red LED will momentarily turn off. When entering long commands, watch the LED to ensure each key press is received properly.

The ADS-SR1 responds to commands with four distinct tone sequences:

High triple-beep – 'Ok - Command was accepted.

High-high-low – 'Negative' - Command was accepted, with negative results.

High-low – 'Error' - Unknown command, or invalid entry.

Low-low – 'Locked' - The security code must be entered first.

Entering Times

For most commands requiring units of time, you can use one of three entry modes:

MM – Two digit value in minutes (e.g., '10' = 10 minutes)

SSS – Three digit value in seconds (e.g., '030' = 30 seconds)

HHMM – Hours and minutes, up to 12 hours (e.g., '0130' = 1 hour 30 minutes)

A quick reference sheet is included at the end of this manual. We strongly recommend cutting out this sheet, folding it, and storing it in the ADS-SR1's battery compartment. If you plan to store the unit for long periods with lithium batteries installed, use the back of the sheet to track battery replacement dates.

Command Reference

##00 – Lock Repeater

Activates the security code and prevents entry of most commands until the access code is entered.

##01 – Ping

Always responds with a triple-beep. Use to test that the unit is unlocked and responding properly to commands.

##02 – Check Voicemail

See below for more information on retrieving voicemail messages.

##06<time> – Set Auto-Off Timer

The repeater function automatically shuts off after the specified idle interval, and may be turned on again with '3' or off with '6'. These on and off functions do not require the access code to be entered. Setting the auto-off timer to 0 disables this function.

Example: ##06045 – Set timer to 45 seconds

##07<code> – Set Voicemail Access Code

Sets the 3-digit access code that grants access only to the voicemail retrieval menu. The code must be entered twice. The default code is '000'.

Example: ##07123123 – Set code to '123'

##08<code> – Set Security Code

Sets the 3-digit access code for all normal commands. As with the voicemail code, this must be entered twice. If the code is lost, the unit can be unlocked by using the reset switch, detailed below, to restore it to its default of '000'.

Example: ##08123123 – Set code to '123'

##09<time> – Set Auto-Lock Timer

If the auto-lock timer is not set to zero, the unit will automatically lock itself after the specified time interval if no commands are entered during that time.

Example: ##09030 – Set timer to 30 seconds

##107<n> – Set Audio Input Gain

If the audio level from the radio is too low, this setting can be used to increase the gain in software. ##1070 sets 1x gain, ##1071 is 2x, and ##1072 is 4x. Note that this setting does *not* affect the VOX threshold. The unit must be reset for this setting to take effect.

Example: ##1071 – Sets 2x gain

##109<n> – COR / Squelch Input Mode

Some radios provide a ‘carrier operated relay’, ‘carrier operated switch’, or other squelch output. Set this option to 0 for VOX operation, 1 for an active-high input, and 2 for an active-low input.

Example: ##1091 – Enable squelch input, active high

##11<nn> – Set Transmit Audio Level

Sets the transmitted audio level, from 00 to 99. Avoid using low numbers, as this decreases sound quality. Set the level first using the DIP switches, and then use this setting as a fine adjustment.

Example: ##1150 – Audio level 50%

##12<n> - Select Courtesy Tone

The ADS-SR1 will transmit a courtesy tone or ‘roger’ beep after every transmission, if enabled. This command selects the style of tone to use.

- 0 – No tone
- 1 – Rising triple tone (default)
- 2 – High-high-low-low
- 3 – High-low
- 4 – Low-high
- 5 – Triple beep
- 6 – Single beep

##13<nn> - Set VOX Timeout

This setting, in 10ths of a second, controls how long the repeater will listen for silence before deciding that a transmission has ended. Setting this too low will cause the repeater to start transmitting during short pauses in speech, and setting it too high will cause unnecessary delay. The default is 2 seconds.

Example: ##1335 – Set timeout to 3.5 seconds

##14<1/0> – Say-Again Mode On/Off

Enables or disables 'say again' mode. Pressing '0' will cause the repeater to retransmit the last transmission heard when this mode is enabled.

Example: ##141 – Enable 'say again' mode.

##16<1/0> – Voice ID On/Off

Turns voice ID auto-response on or off. When enabled, the repeater will play announcement 0 in response to a transmission. Like the Morse ID, an inhibit timer (set with the ##85 command) can be used to ensure the voice ID plays no more often than specified. This message can also be used to transmit instructions on use of the repeater or voicemail functions.

Example: ##161 – Voice ID on

##16<3/2> – Voice Preamble On/Off

The voice preamble function causes the repeater to send message 1 at the start of each repeated transmission.

Example: ##163 – Voice preamble on

##164 – Disable 'Stand By' Message

Turns off the 'stand by' tone or message.

##165[n] – Enable 'Stand By' Tone or Message

The repeater will send the selected message (or a double beep if no message is selected) when an incoming transmission is received. This alerts other users that the repeater is in use. Because the repeater must key the transmitter for the duration of the beep or message, the first portion of the incoming transmission will be lost, so keep the 'stand by' message short.

Example: ##165 – Use 'stand by' beep ##1651 – Use message '1'

##16<9/8> – Voice ID Rotation On/Off

When this option is enabled, the voice ID auto-response message will cycle through each recorded announcement, except message 1 if the preamble option is enabled.

Example: ##168 – Voice ID rotation off

##17<time> - Repeater Timeout

Sets the maximum transmission length allowed. If an incoming transmission exceeds this length, the repeater will stop recording and start re-transmitting it immediately.

Example: ##17045 – Set repeater timeout to 45 seconds

##18<time> - Repeater Cool-down Time

If the repeater times out due to a long transmission, it will stop repeating transmissions until the period of time specified by this setting has expired. This can be used to avoid transmitter overheating, to ensure that a repeater with a stuck squelch remains controllable, or to penalize overly long-winded users.

Example: ##1802 – Set cool-down time to 2 minutes

##19<nn> - Set Minimum Transmission Time

This setting specifies, in tenths of a second, how long a transmission must be before it will be repeated. This can be used to avoid 'kerchunking' of the repeater. When using the repeater to check for missed calls with the 'say again' feature, setting this number higher will prevent short transmissions from overwriting the 'say again' memory. Default is 0.2 seconds.

Example: ##1904 – Set minimum transmission time to 0.4 seconds

##2<n> - Play Announcement

Plays the specified announcement (0-9), or a 'negative' beep if the announcement is blank.

Example: ##21 – Play announcement 1

##3<n> - Record Announcement

Records an announcement in the specified slot (0-9). If an announcement already exists in the slot, the old message is erased and replaced. The repeater will respond with an 'ok' beep. Transmit your message after the 'ok' beep, and the repeater will respond by playing an 'ok' beep, followed by the message just recorded.

Example: ##31- Record announcement 1

##4<n> - Erase Announcement

Erases the specified announcement (0-9).

Example: ##41 –Erase announcement 1

##5<n><time> - Set Announcement Interval

If the interval for an announcement is not zero, it will be played automatically at that interval. The time range can be from one second to twelve hours.

Example: ##530100 – Set announcement 3 interval to 1 hour

##6<n><time> - Set Announcement Time Offset

Without the use of a time offset, all announcements with the same interval would play at the same time. Use the offset to stagger messages. For example, to alternate between messages 1 and 2 every five minutes, set both to interval 10, and then set the offset for message 2 to 5. Message 1 will transmit at 00:00, message 2 at 00:05, message 1 again at 00:10, message 2 at 00:15, and so on.

Example: ##6410 – Set announcement 4 offset to 10 minutes

##70 – Repeater Off

Turns off the simplex repeater function. The unit will respond to commands, record 'say again' messages, play announcements, and accept voicemail as usual, but it won't automatically repeat transmissions.

##71 – Repeater On

Turns on the simplex repeater function. The unit will automatically repeat transmissions. The repeater is turned on by default.

##72 – Voicemail Off

Turns off the voicemail function. Existing messages will be retained and can be retrieved, but messages cannot be recorded. The voicemail function is turned off by default.

##73 – Voicemail On

Turns on the voicemail function. Pressing '1' will record a new voicemail message.

##74 – Erase All Voicemail Messages

Erases all voicemail messages.

##77<1/0> - Courtesy Tone Delay On/Off

Some radios produce a beep at the end of each transmission that can cause the repeater to get stuck in a continuous transmission cycle. Enabling this option causes the repeater to ignore audio for one second after each transmission.

Example: ##771 –Enable courtesy tone delay

##78<code> - Set Pager Activation Code

The pager activation code can be up to 6 characters long. When a code is entered, the repeater will ignore all received transmissions unless the DTMF activation code is heard. This can be used to extend voice pager systems, or to activate the repeater using a DTMF ANI setting on the sending radio. Setting a blank code disables the function.

Example: ##781234 – Set pager activation code to ‘1234’.

##79<nn> - Squelch Tail Suppression Time

If your radio has a slow squelch, you may hear a static crash at the end of each repeated transmission. Set this option in 1/75 second units to reduce or eliminate this noise.

Example: ##7910 – Repeater will ignore last 10/75 (0.133) second of each transmission

##15<1/0> – CW ID Auto-Responder On/Off

Enables or disables CW ID auto-response. The repeater will respond to a transmission with a Morse code ID (set with the ##82 command) when enabled. If the CW ID inhibit timer (##84) is set, the ID response will be sent only as often as specified by that timer setting.

Example: ##150 – CW ID off

##80<1/0> - Timed CW ID On/Off

##801 turns on the timed Morse code ID, and ##800 turns it off. This ID function is separate from the CW ID auto-response function. When enabled, the ID will be transmitted at the programmed interval regardless of activity.

Example: ##801 – Turn on CW ID

##83<time> - Set CW ID Timer

Sets the time interval for Morse code IDs. This option is enabled with the ##80 command, and is independent of the auto-response ID.

Example: ##8310 – Set CW ID time to 10 minutes

##84<time> - Set CW ID Inhibit Timer

When the Morse code ID auto-response feature (##151) is enabled, this timer determines how often the ID will be sent in response to a transmission. For example, if the timer is set to 10 minutes, the ID will be sent in response to the first transmission heard, and not again until at least 10 minutes have passed and another transmission is heard.

Example: ##8405 – Set CW ID inhibit timer to 5 minutes

##81<nn> - Set CW Speed

Sets the transmission speed for Morse code messages. Accepted values are 00-99, ranging from very slow to very fast. Default is 80.

Example: ##8195 – Set CW speed to 95% (very fast)

##82<nn...> - Set CW ID Text

Sets the text to be transmitted in Morse code for the timed and auto-response ID functions, up to 12 characters. Each character is entered as a two-digit number, from the following table:

00	Space	24	X
01	A	25	Y
02	B	26	Z
03	C	27	. (Period)
04	D	28	, (Comma)
05	E	29	?
06	F	30	0
07	G	31	1
08	H	32	2
09	I	33	3
10	J	34	4
11	K	35	5
12	L	36	6
13	M	37	7
14	N	38	8
15	O	39	9
16	P	40	; (Semicolon)
17	Q	41	: (Colon)
18	R	42	/ (Slash)
19	S	43	- (Dash)
20	T	44	' (Apostrophe)
21	U	45	((Left parenthesis)
22	V	46) (Right parenthesis)
23	W	47	_ (Underscore)

Example: ##8223310123 – Set ID to W1AW

##86 – Check CW ID

Plays the Morse code ID entered by the ##82 command.

##85<time> - Set Voice ID Inhibit Timer

As with the CW ID inhibit timer, this timer prevents the voice ID auto-response from playing more often than the specified interval.

Example: ##8508 – Set voice ID inhibit timer to 8 minutes

##91 – Identify Firmware Revision

Sends a firmware revision identifier in Morse code.

##93xy – Set Output Pin State

Sets output pin x (0 or 1) on (1) or off (0). See ‘Output Pins’ section below for more information.

Example: ##9301 – Set output pin 0 on

##95 – Report Battery Level

The repeater responds to this command with a series of beeps to indicate the battery voltage. Full batteries should report more than 15 beeps. The unit may not continue to operate all the way to one beep. This command only functions when the unit is on internal battery power.

##96 – Report Usage Count

Reports, in Morse code, the number of times the repeater has been used since being powered on.

##97 – Load Default Settings

Resets all settings to factory defaults and erases all voicemail messages and announcements.

##98 – Send Calibration Tone

Transmits a 1 kHz tone at full amplitude for several seconds. This command can be used to set audio levels precisely using a service monitor.

##99 – Reset

Resets the unit as if powered off and on again. Does not affect settings or recorded messages.

Using Voicemail

The ADS-SR1's voicemail functions are disabled by default. Use the ##73 command to turn on voicemail and allow users to record messages.

When the voicemail function is on, users can record a message by pressing '1'. The unit will respond with an 'ok' beep, after which the user can transmit their message. The ADS-SR1 will transmit another 'ok' beep and then the message just recorded.

You can enter voicemail retrieval mode using the ##02 command (if the unit is unlocked), or by entering * followed by the 3-digit voicemail access code. The unit will respond by playing the first message, or a 'negative' beep if there are no messages.

While in voicemail retrieval mode, five commands are available:

- 1 – Play previous message
- 2 – Repeat current message
- 3 – Play next message
- 0 – Erase current message and play next message
- * – Exit voicemail retrieval mode

If no command is entered, after ten seconds the unit will exit voicemail retrieval mode. The unit also automatically exits this mode when the last message is played, as indicated by a 'negative' beep.

Resetting to Defaults

If you forget the access code, or for any other reason need to restore the unit to its factory default settings, turn the device off, set DIP switch 3 (located in the battery compartment) to the 'on' position, and turn the device on again. The red and green LEDs will light in sequence and then flash together, indicating a successful reset. You can then set the DIP switch back to the 'off' position.

Squelch Input

The squelch input can be enabled in active-high or active-low mode. The input threshold is approximately two volts. If an open collector input is used, an external pull-up resistor is required. The input voltage should not exceed 30 volts.

If the unit is connected to an unsquelched audio source, unplug the cable briefly after sending the squelch mode command. This will give the repeater a chance to process the received command and set the appropriate mode.

If you inadvertently set the wrong squelch mode and leave the unit in a state where it can't receive commands, you can restore the default settings using the procedure described in the 'Resetting to Defaults' section.

Once the squelch mode has been properly set, it is safe to set the VOX timeout to zero, allowing retransmission without a pause. If unsquelched audio is used and the squelch signal is too slow, repeated transmissions may include a burst of static at the end. You can use the squelch tail suppression option to prevent this.

DIP Switches

Four DIP switches are located in the battery compartment. The switches are numbered 1-4, starting from the side nearest the power switch. The 'on' position is down, toward the battery compartment door. The functions of all four are described in detail elsewhere in this manual.

- 1 – Audio level (on = higher)
- 2 – Audio level (on = higher)
- 3 – Reset to defaults at power-on
- 4 – PTT mode (on = PTT/mic combined)

Output Pins

Two general-purpose output pins on pin header JP2, located in the lower-right corner of the circuit board, can be controlled with the ##93 command. Output 0 is pin 5 of the header, in the lower right position, and output 1 is pin 3, immediately to the left. The 'on' state is 3 volts, and 'off' is zero. Output settings are retained in non-volatile memory and are restored at power-on.

Firmware Updates

Firmware updates with feature enhancements and bug fixes are available through the Argent Data Systems website at <http://www.argentdata.com/support>. Updates to the ADS-SR1 are provided in the form of audio files that are played back to the device through its radio interface. A 3.5mm phone plug wired to an RJ45 connector will allow the ADS-SR1 to be connected to a PC's sound card, CD player, or similar audio source. The green LED will begin blinking as the unit receives the firmware file, and when the download is complete and has been verified, both LEDs will light briefly and the unit will reset. Newer units will enter a rapid red/green blinking mode to indicate a successful update; turn the power off and back on again to reset the unit.

If the update does not complete, it may have missed one or more blocks of data. Simply replay the update until it takes. You can verify that the update worked by using the ##91 command to check the firmware revision.

Keep in mind that firmware updates may cause the ADS-SR1 to revert to its default settings, and/or erase stored messages.

Revision History

- Revision B: Initial public release
- Revision C: Added calibration tone command (##98)
- Revision D: Added COR / squelch input option
 - Setting VOX timeout to zero no longer disables reception
 - Added battery status command
 - Added squelch tail suppression option
 - Added courtesy tone #5
 - Lowered power consumption in idle mode
 - Added output pin control option
- Revision E: Added beep ignore and pager activation options
- Revision H: Bug fixes, support for new flash ICs
 - Preamble and usage count functions added
- Revision J: Improved DTMF decoding
 - Added 'standby' message function
 - Added voice follow message rotation
 - Fixed bugs causing occasional garbled recording
- Revision K: Fixed timed announcement and voicemail access bugs
 - Added auto-off and unauthenticated ON command

Schematic Diagram

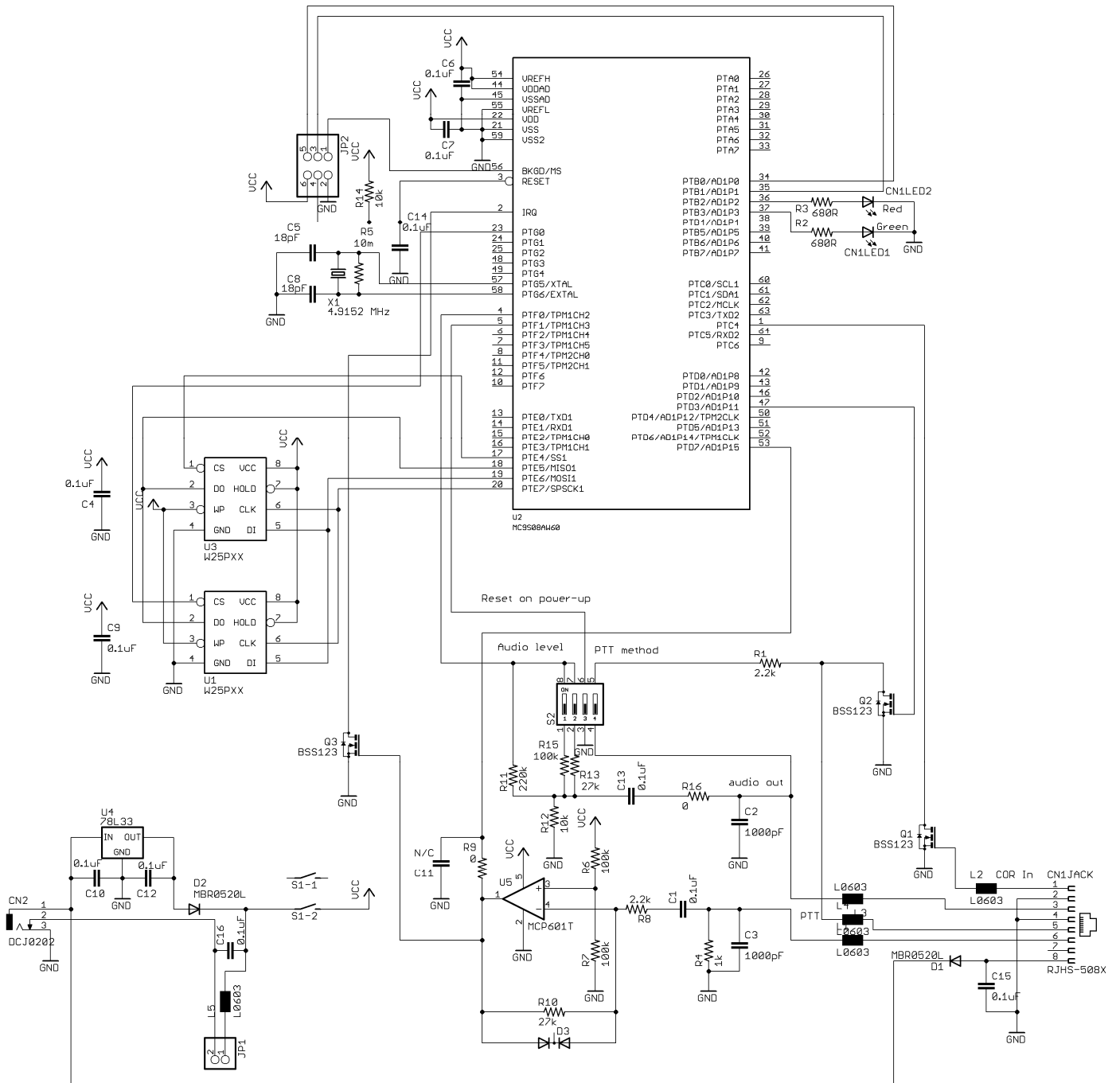

Quick reference sheet - cut out, fold, and store in battery compartment.

Commands

* - Abort Entry
0 - Say Again
3 - Repeater On
6 - Repeater Off

##00 - Lock Repeater
##06<time> - Set Auto-Off Timer
##08<code twice> - Set Security Code
##78<code> - Set activation code
##09<time> - Auto-Lock Timer
##7<0/1> - Repeater off/on
##7<2/3> - Voicemail off/on
##14<0/1> - Say-Again off/on
##16<4/5><n> - Standby message off/on/select

##11<nn> - Transmit Audio Level
##107<n> - Input Gain (0=1x,1=2x,2=4x)
##109<n> - Squelch Mode
(0=VOX,1=HI,2=LO)
##13<nn> - VOX Timeout (1/10 second)
##19<nn> - Min. Transmission Time (1/10 sec)
##79<nn> - Squelch Tail Suppression (1/75 sec)
##17<time> - Repeater Timeout
##18<time> - Cool-down Time
##12<n> - Courtesy Tone

##16<0/1> - Voice ID off/on
##16<8/9> - Voice ID rotate on/off
##85<time> - Voice ID Inhibit Timer
##16<2/3> - Voice preamble off/on

##2<n> - Play Announcement
##3<n> - Record Announcement
##4<n> - Erase Announcement
##5<n><time> - Announcement Interval
##6<n><time> - Announcement Time Offset

##80<0/1> - CW ID off/on
##81<nn> - CW Speed
##82<nn...> - CW ID
(_=0,A=1,Z=26,0=31,9=39)
##86 - Check CW ID
##83<time> - CW ID Timer
##15<0/1> - CW ID responder off/on
##84<time> - CW ID Inhibit Timer

##01 - Ping (Responds with beep)
##91 - Identify Firmware Revision
##93xy -- Set output in x to state y
##95 - Report Battery Level
##96 - Report usage count
##97 - Load Default Settings
##98 - Send Calibration Tone (1 kHz)
##99 - Reset

Voicemail
##02 - Check Voicemail
##07<code twice> - Set Voicemail Code
##74 - Erase All Voicemail Messages
*<code> or ##02 to check
1 - Play previous message
2 - Repeat current message
3 - Play next message
0 - Erase message and play next
* - Exit voicemail mode

DIP switches
#1 nearest power switch, down is on
1 & 2 - Audio level (on = higher)
3 - Reset to defaults at power-on
4 - PTT mode (on = HT mode)

Pinouts
From front, left to right
8 - Power in
6 - Audio in
5 - PTT
4 & 2 - Ground
3 - Audio out
1 - Squelch/Busy in

